

1:5

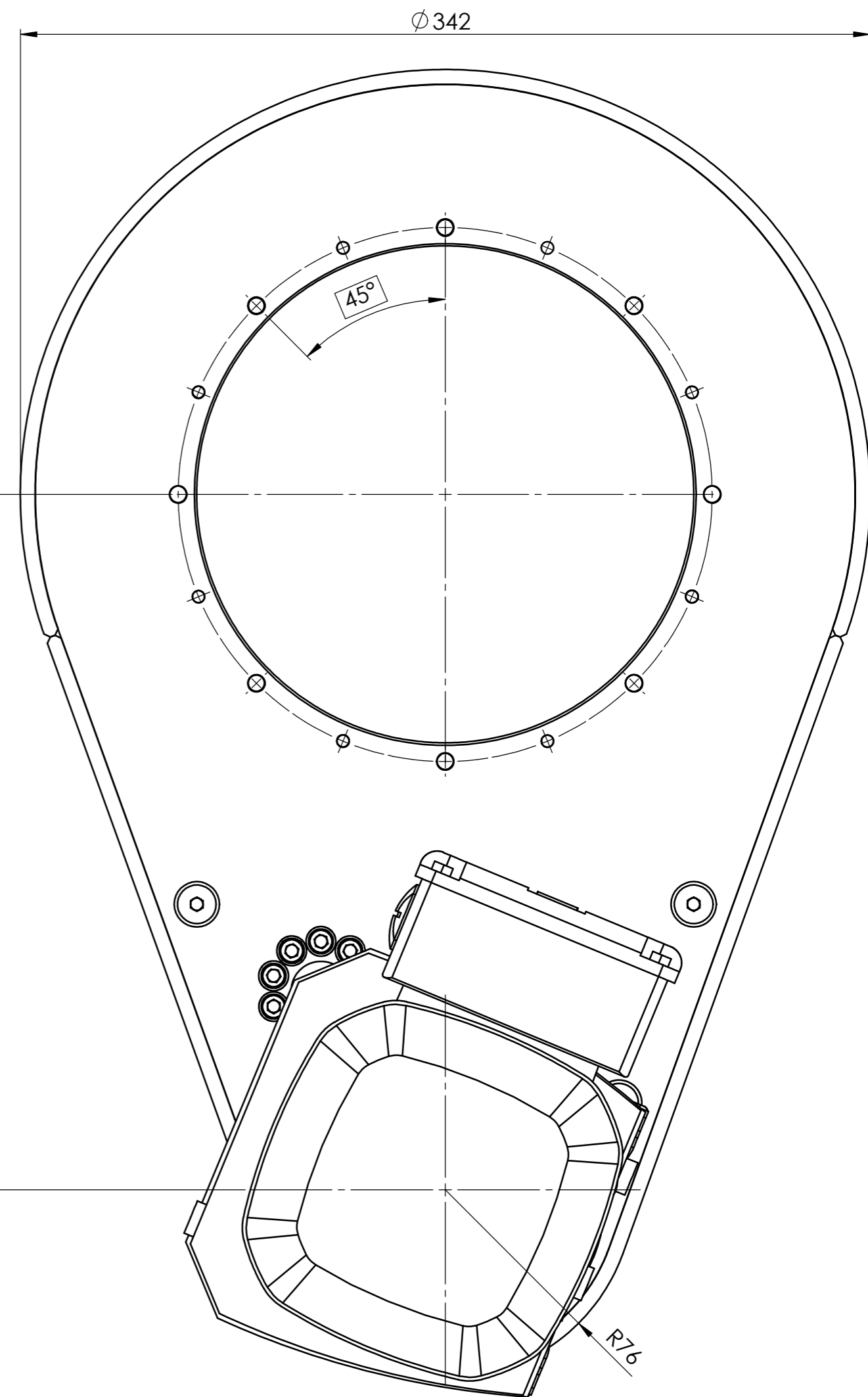

RF37 DRS71 M4

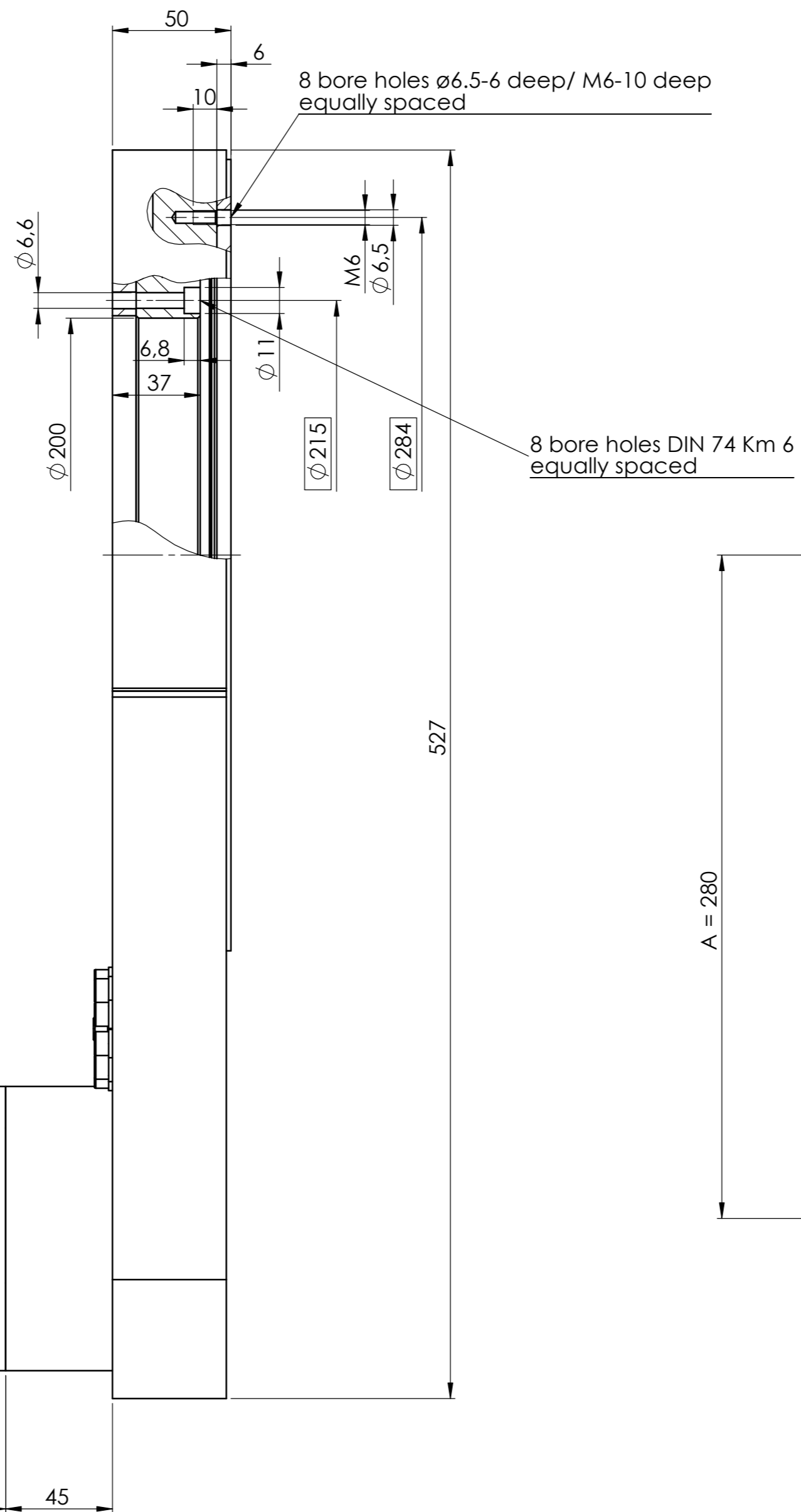
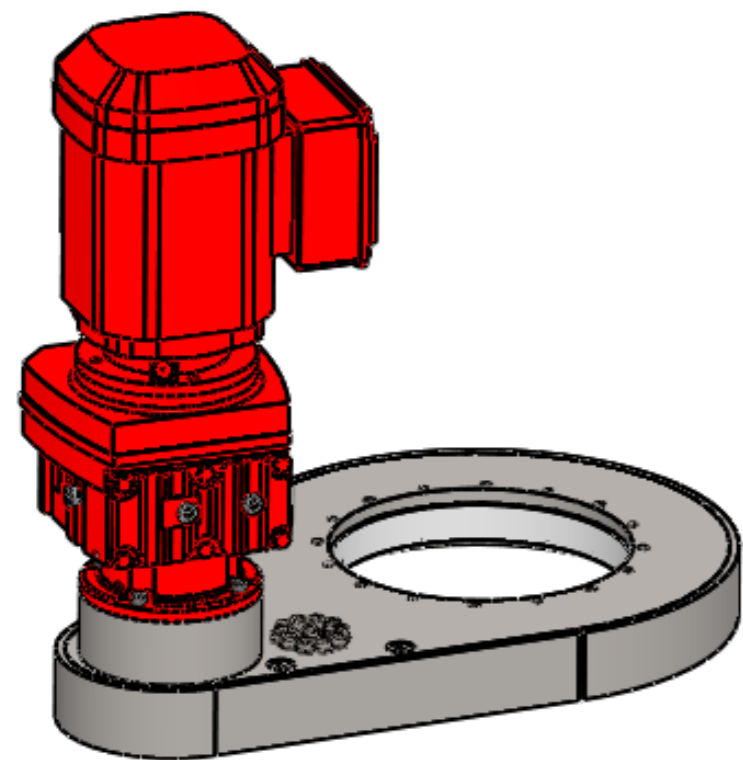
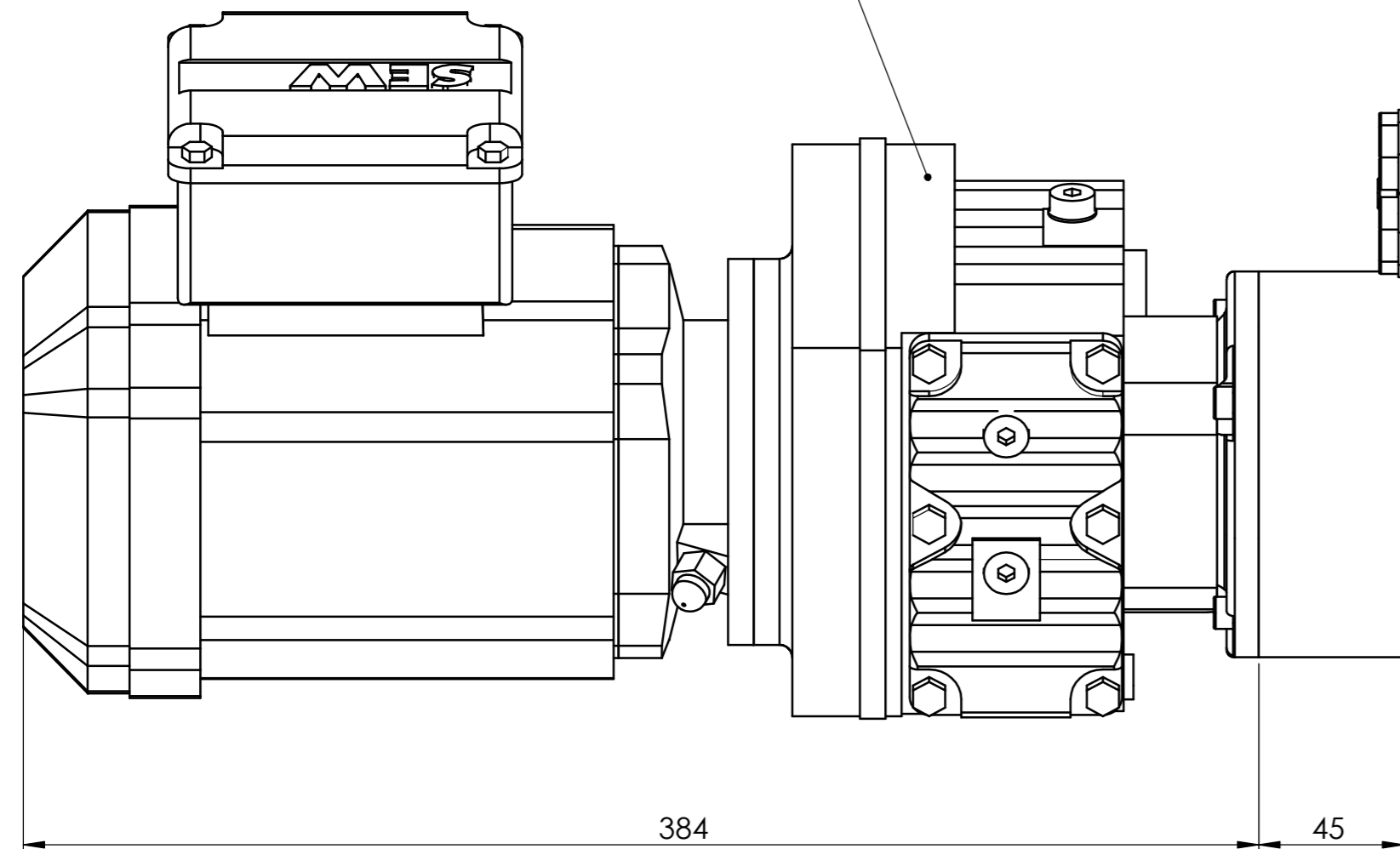

For information only

Auftragsnummer:		Allgemeintoleranzen DIN ISO 2768-mK		 DIN 6 T1 - Proj.methode 1		Maßstab: 1:2		Gewicht: 33.08Kg	
Oberflächenbehandlung:		Datum		Name		Material: Material <nicht festgelegt>		Rohabmessung:	
Wärmebehandlung:		Erstellt 03.03.2016		U. Klinner		Projekt:		Benennung:	
Schutzvermerk ISO 16016 beachten		Gepr.		Norm.		Zahnriementrieb Timing belt drive		Zeichnungsnummer:	
Zust.		Änderungen		Datum		Name		Status	
								Format	
								Blatt / von	
								Blatt2/2	
								Version	
								2012	
								Sonstiges:	
								11	

UKlin Drives GmbH  
Hafenstraße 8  
91301 Forchheim  
Germany  
info@uklin-drives.de

ZRT 0280-00145-00

Status  
Format  
A2  
Blatt / von  
Blatt2/2